



佰嘉汇科技

# LED 球场灯规格书

LED Stadium Light Datasheet



PRODUCT NAME 产品名称	800W 球场灯
PRODUCT NO 产品型号	BJH-QC-800W-B

佰嘉汇科技  
BAIJIAHUI

地址：深圳市宝安区福海街道蚝业路39号旭竟昌工业园B6栋3层  
电话：15989497850 / 0755-23309606  
传真：0755-23309676  
邮箱：szbjhkj@163.com  
网址：www.szbjkhkj.com

# 产品规格 ( Product Spec ) : BJH-QC-800W-B

电气特性 ( Electrical Characteristics )		光学特性(Optical Properties)		
电源 Power Supply	Normal / MEAN WELL	光源 LED Type	Sanan / LUMILEDS 5050	
输入电压 Input Voltage	AC100-305V /50-60Hz	光源数量 LED Q' ty	480pcs	
额定功率 Rated Power	800W	流明值 Lumen	112000LM±5%	
功率因素 Power Factor	0.97	显色指数 CRI	>70 Ra	
防护等级 Waterproof	IP66	发光角度 Beam Angle	10°/25°/45°/60°	
使用寿命 Life Time	≥50000H	色温 CCT	warm white	3000K
				4000K
			Natural white	5000K
			Pure white	5700K
			6500K	
产品材质 ( Product Material )				
电源线 Power Wire	外壳材质 Body material	电气安全等级 Electronic safety grade		
3*1.2mm²*1M 橡胶线 (Rubber cable L=1M)	铝 + PC Aluminum + PC	I类 ( class)		
工作温度 Working Temperature	-30~ +60°C			
LED 结温 LED Junction Temperature	≤80°C			
安全要求 Security Requirement	CE			
环保指令 Environmental Directives	ROHS			
产品尺寸 Product Dimension	620*645*380mm			
净重 N.W	30.6KG			

## 灯具照度 ( Lamp illumination ) :

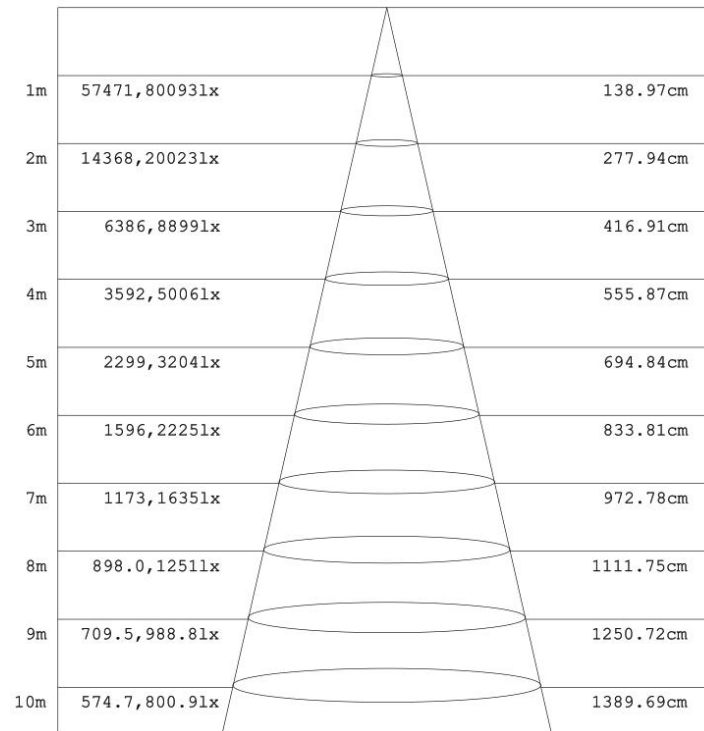

## 灯具尺寸 ( Lamp Size ) :

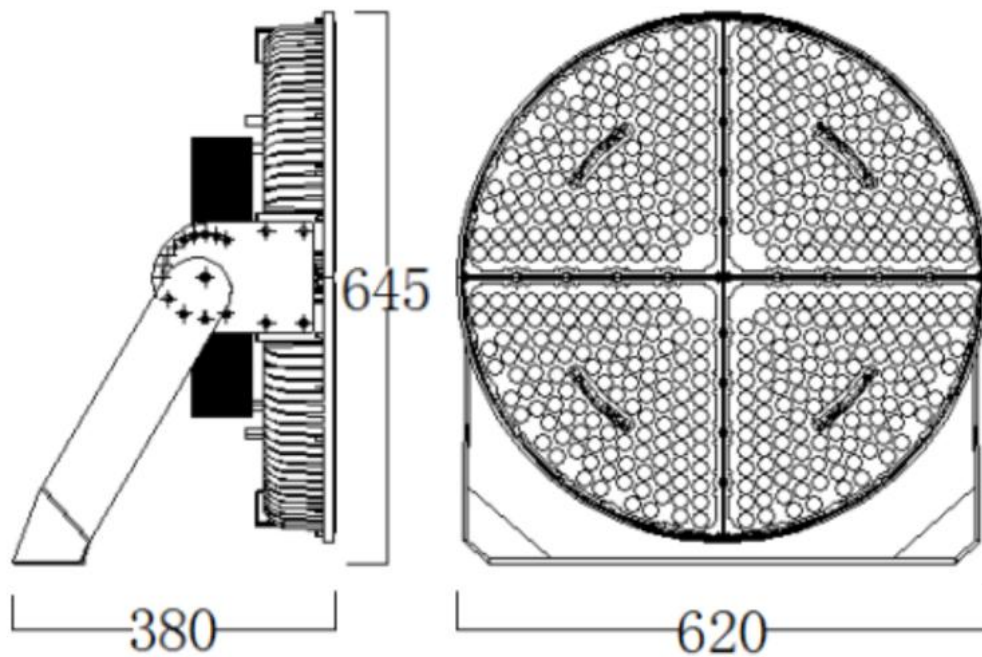

## 包装 ( Package ) :

外箱尺寸 ( Packing Box ) : 86\*68\*26CM

材质 Material : K=K

装箱数量 ( QTY ) : 1 PCS/CTN

重量 ( G.W ) : 32.6KG