



佰嘉汇科技

LED 隧道灯规格书

LED Tunnel Light Datasheet



PRODUCT NAME 产品名称	100W 隧道灯
PRODUCT NO 产品型号	BJH-TL-100W-A

佰嘉汇科技
BAIJIAHUI

地址：深圳市宝安区福海街道蚝业路39号旭竟昌工业园B6栋3层
电话：15989497850 / 0755-23309606
传真：0755-23309676
邮箱：szbjhkj@163.com
网址：www.szbjhkj.com

产品规格 (Product Spec) : BJH-TL-100W-A

电气特性 (Electrical Characteristics)		光学特性(Optical Properties)		
电源 Power Supply	Normal / MEAN WELL	光源 LED Type	Epistar/ OSRAM /LUMILEDS 3030	
输入电压 Input Voltage	AC100-277V /50-60Hz	光源数量 LED Q' ty	128 pcs	
额定功率 Rated Power	100W	流明值 Lumen	13000LM±5%	
功率因素 Power Factor	0.95	显色指数 CRI	80 Ra	
防护等级 Waterproof	IP66	发光角度 Beam Angle	60°/90°/60*150°	
使用寿命 Life Time	≥50000H	色温 CCT	warm white	3000K
				4000K
			Natural white	5000K
			Pure white	5700K
				6500K
产品材质 (Product Material)				
电源线 Power Wire	外壳材质 Body material		电气安全等级 Electronic safety grade	
3*0.75mm²0.5M 橡胶线 (Rubber cable L=0.5M)	铝 + PC Aluminum + PC		I类 (class)	
工作温度 Working Temperature		-30~ +60°C		
LED 结温 LED Junction Temperature		≤80°C		
安全要求 Security Requirement		CE		
环保指令 Environmental Directives		ROHS		
产品尺寸 Product Dimension		315*238*130mm		
净重 N.W		4KG		

灯具照度 (Lamp illumination) :

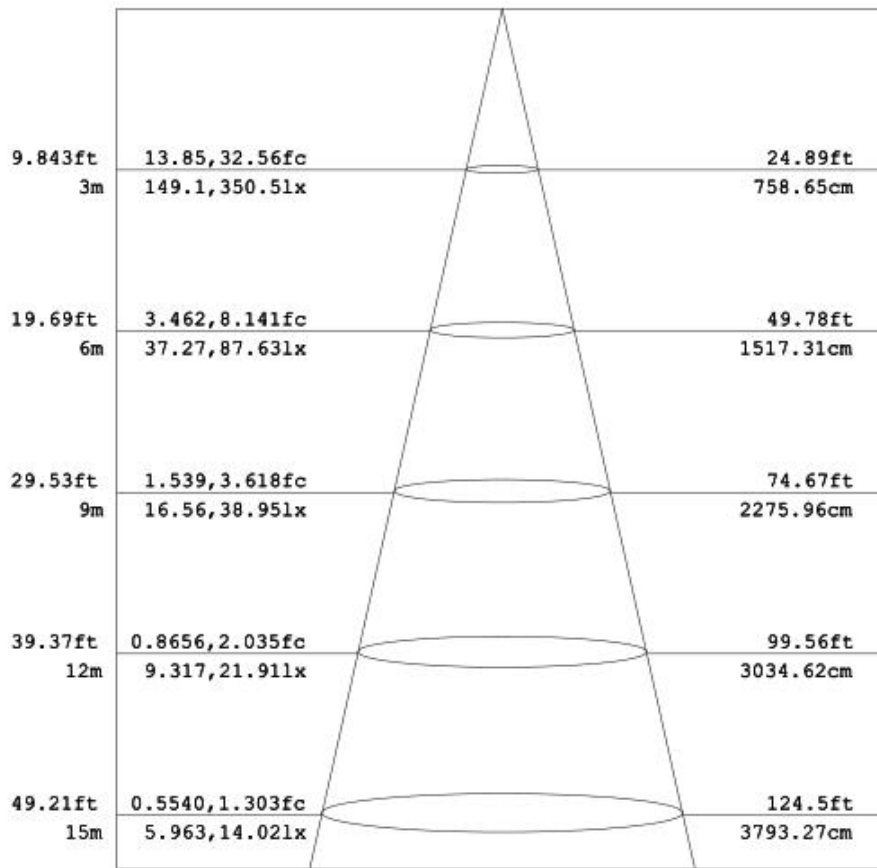

灯具尺寸 (Lamp Size) :

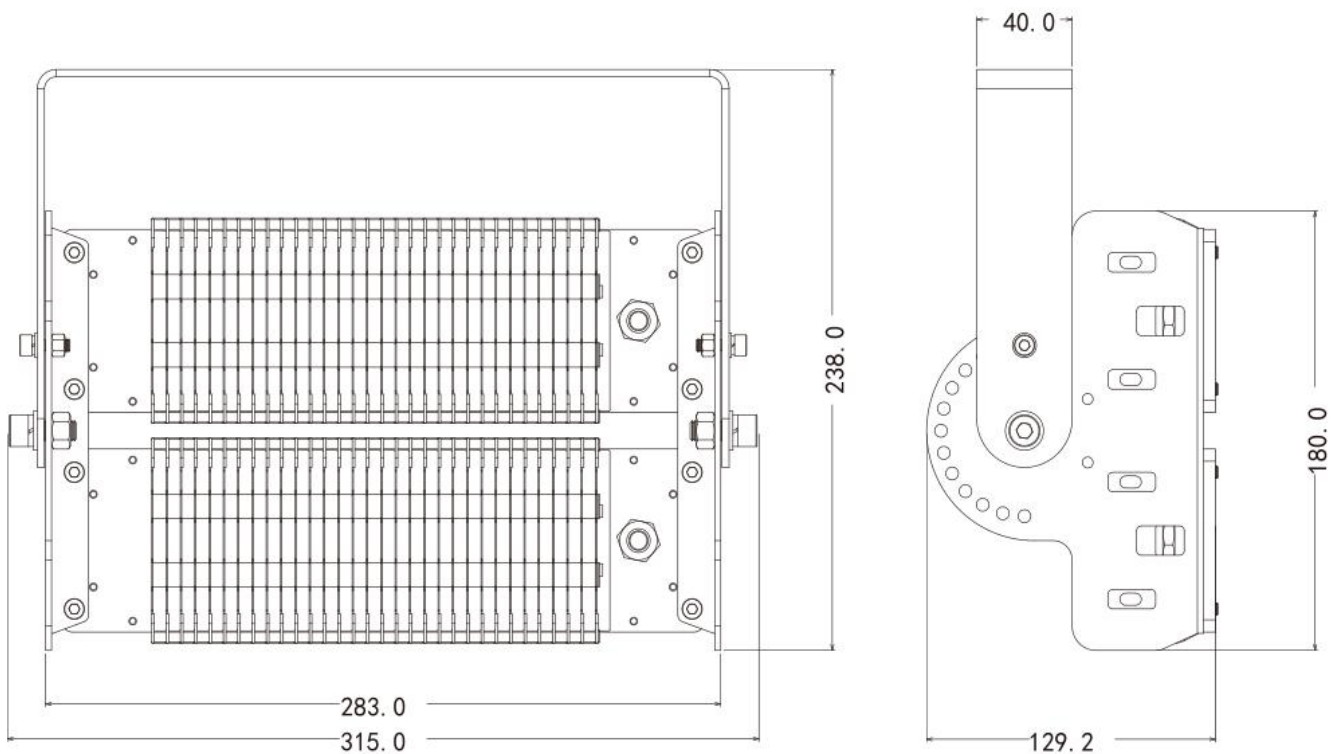

包装 (Package) :

外箱尺寸 (Packing Box) : 34*25*16CM

材质 Material : K=K

装箱数量 (QTY) : 1 PCS/CTN

重量 (G.W) : 5 KG